

**Art. 39A**

**Riduzione concentrica a saldare lucida**

Welding concentric reducer

Reduction concentrique a souder

Konzentrisch reduziertstück zum anschw.

**Art. 39C**

**Riduzione eccentrica a saldare lucida**

Welding eccentric reducer

Reduction excentrique a souder

Exzentrisch reduziertstück zum anschw.

DN	A1	A2	B	C	Sp.A1	Sp.A2	PN
15/10	18	12	12		1,5	1,5	25
20/15	22	18	8		1,5	1,5	25
25/20	28	22	11/30	11/30	1,5	1,5	25
25/15	28	18	18/30	18/30	1,5	1,5	25
25/10	28	12	30		1,5	1,5	25
32/25	34	28	11/40	11/60	1,5	1,5	25
32/20	34	22	23	23	1,5	1,5	25
32/15	34	18	29		1,5	1,5	25
40/32	40	34	12/38	12/50	1,5	1,5	25
40/25	40	28	22/52	22/50	1,5	1,5	25
40/20	40	22	33		1,5	1,5	25
50/40	52	40	23/63	23/50	1,5	1,5	25
50/32	52	34	33/79	33/75	1,5	1,5	25
50/25	52	28	45/84	80	1,5	1,5	25
50/20	52	22	56		1,5	1,5	25
65/50	70	52	32/45	32/65	2	1,5	16
65/40	70	40	55/60	55/80	2	1,5	16
65/32	70	34	64		2	1,5	16
65/25	70	28	76		2	1,5	16
80/65	85	70	27/50	27/40	2	2	16
80/50	85	52	55/60	60	2	1,5	16
80/40	85	40	84		2	1,5	16
80/32	85	34	93		2	1,5	16
100/80	101,6	85	31/50	35/60	2	2	16
100/65	101,6	70	57/58	61/85	2	2	16
100/50	101,6	52	139		2	1,5	16
100/40	101,6	40			2	1,5	16
100/80	104	85	35/50	60	2	2	16
100/65	104	70	57/63	85	2	2	16
100/52	104	52	145		2	1,5	16

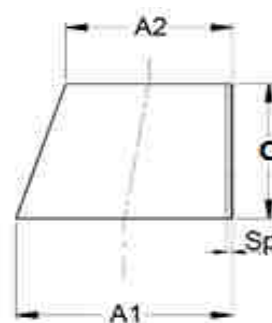
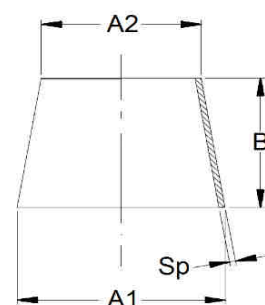

DN	A	C	B	C	Sp.A1	Sp.A2	PN
1"1/2 - 1"	38,1	25,4	40/57	39/60	1,5	1,5	25
2" - 1"1/2	50,8	38,1	41/47	39/50	1,5	1,5	25
2" - 1"	50,8	25,4	65/80	70	1,5	1,5	25
2"1/2 - 2"	63,5	50,8	37/38	38/45	1,5	1,5	25
2"1/2 - 1"1/2	63,5	38,1	60/80	76/80	1,5	1,5	25
3" - 2"1/2	76,2	63,5	27/38	35/38	2	1,5	16
3" - 2"	76,2	50,8	45/76	70/76	2	1,5	16
3" - 1"1/2	76,2	38,1	60/113		2	1,5	16

Finitura: lucida est. - satinata int.

Finishing : polished out. - satinized ins.

Finissage : poli ext. - satiné int.

Zurichten : aus. Poliert - inn. satiniert

**Art. G39A**

**Riduzione concentrica a saldare grezza**

Welding concentric reducer

Reduction concentrique a souder

Konzentrisch reduziertstück zum anschw.

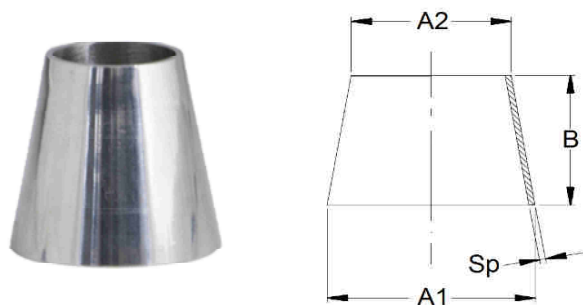

**Art. G39C**

**Riduzione eccentrica a saldare grezza**

Welding eccentric reducer

Reduction excentrique a souder

Exzentrisch reduziertstück zum anschw.

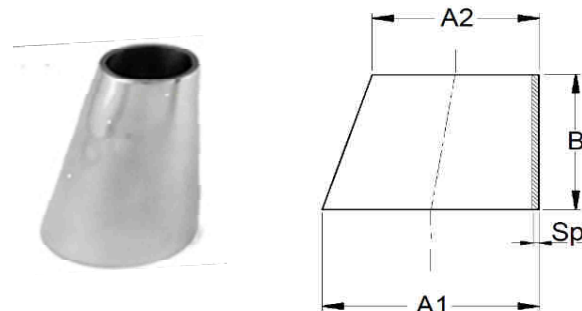

DN	A1	A2	B	Sp.	DN	A1	A2	B	Sp.
1/2" X 3/8"	21,3	17,2	28	2-3	4" X 3"	114,3	88,9	102	2-3
3/4" X 1/2"	26,9	21,3	38	2-3	4" X 2 1/2"	114,3	76,1	102	2-3
3/4" X 3/8"	26,9	17,2	38	2-3	4" X 2"	114,3	60,3	102	2-3
1" X 3/4"	33,7	26,9	51	2-3	4" X 1 1/2"	114,3	48,3	102	2-3
1" X 1/2"	33,7	21,3	51	2-3	4" X 1 1/4"	114,3	42,4	102	2-3
1" X 3/8"	33,7	17,2	51	2-3	4" X 1"	114,3	33,7	102	2-3
1 1/4 X 1"	42,4	33,7	51	2-3	5" X 4"	139,7	114,3	127	2-3
1 1/4 X 3/4"	42,4	26,9	51	2-3	5" X 3"	139,7	88,9	127	2-3
1 1/4 X 1/2"	42,4	21,3	51	2-3	5" X 2 1/2"	139,7	76,1	127	2-3
1 1/2" X 1 1/4"	48,3	42,4	63	2-3	5" X 2"	139,7	60,3	127	2-3
1 1/2 X 1"	48,3	33,7	63	2-3	6" X 5"	168,3	139,7	140	2-3
1 1/2 X 3/4"	48,3	26,9	63	2-3	6" X 4"	168,3	114,3	140	2-3
1 1/2 X 1/2"	48,3	21,3	63	2-3	6" X 3"	168,3	88,9	140	2-3
2" X 1 1/2"	60,3	48,3	76	2-3	6" X 2 1/2"	168,3	76,1	140	2-3
2" X 1 1/4"	60,3	42,4	76	2-3	6" X 2"	168,3	60,3	140	2-3
2" X 1"	60,3	33,7	76	2-3	8" X 6"	219,1	168,3	152	2-3
2" X 3/4"	60,3	26,9	76	2-3	8" X 5"	219,1	139,7	152	2-3
2" X 1/2"	60,3	21,3	76	2-3	8" X 4"	219,1	114,3	152	2-3
2 1/2 X 2"	76,1	60,3	89	2-3	8" X 3"	219,1	88,9	152	2-3
2 1/2 X 1 1/2"	76,1	48,3	89	2-3	10" X 8"	273	219,1	178	2-3
2 1/2 X 1 1/4"	76,1	42,4	89	2-3	10" X 6"	273	168,3	178	2-3
2 1/2 X 1"	76,1	33,7	89	2-3	10" X 5"	273	139,7	178	2-3
2 1/2 X 3/4"	76,1	26,9	89	2-3	10" X 4"	273	114,3	178	2-3
3" X 2 1/2"	88,9	76,1	89	2-3	12" X 10"	323,9	273	203	2-3
3" X 2"	88,9	60,3	89	2-3	12" X 8"	323,9	219,1	203	2-3
3" X 1 1/2"	88,9	48,3	89	2-3	12" X 6"	323,9	168,3	203	2-3
3" X 1 1/4"	88,9	42,4	89	2-3	12" X 5"	323,9	139,7	203	2-3
3" X 1"	88,9	33,7	89	2-3	12" X 4"	323,9	114,3	203	2-3

finitura int./est. 2B  
2B finishing out./ins

Finissage 2B int./ext.  
inn./aus. Zurichten 2B